

**Phys 211 / 211A / 216
Sample Test #3
University Physics I/IA**

NAME: (1 point) _____

Circle your professor:

Curie

Einstein

Feynman

Hawking

Meitner

Noether

Section # or Class Time: _____

Scores: Do not write on this page

0. _____/1 (point for name)

1. _____/3

2. _____/3

3. _____/3

4. _____/3

5. _____/3

6. _____/3

7. _____/3

8. _____/3

14. _____/20

9. _____/3

15. _____/20

10. _____/3

16. _____/20

11. _____/3

12. _____/3

TOTAL/100

13. _____/3

--

Part I: Multiple Choice (3 points each).

Circle one answer for each question in a clear and unambiguous way.

1. The SI (Metric system) unit $\text{kg}\cdot\text{m}^2$ maybe used for

- A. angular momentum
- B. rotational inertia (moment of inertia)
- C. rotational inertia kinetic energy
- D. torque
- E. centripetal (radial) acceleration

2. A wheel is rolling along a road, without slipping or sliding, attached to a car moving with a speed v . A piece of tape is attached to the outer edge of the wheel. When the tape is opposite the road (at the top of the wheel), its speed with respect to the road is

- A. Zero
- B. v
- C. $1.5v$
- D. $2v$
- E. The radius of the wheel is needed to determine this

3. A block is pivoted about its center. A 5.0 N force is applied 4.0 m from the center and another at 2.0 m from the center. Both forces act at 30° as shown. The magnitude of the net torque about the center is

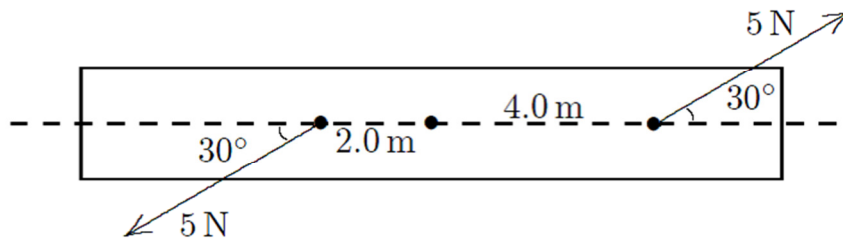

- A. $0 \text{ N}\cdot\text{m}$
- B. $4.3 \text{ N}\cdot\text{m}$
- C. $5.0 \text{ N}\cdot\text{m}$
- D. $13 \text{ N}\cdot\text{m}$
- E. $15 \text{ N}\cdot\text{m}$

4. Consider a long thin rod of uniform density (mass M and length L) that is rotated about an axis that is perpendicular to its length and located one sixth of the length from one end, as shown in the diagram. What is the moment of inertia for the rod about this axis?

- A. $\frac{7}{36}ML^2$
 B. $\frac{11}{36}ML^2$
 C. $\frac{13}{36}ML^2$
 D. $\frac{15}{36}ML^2$

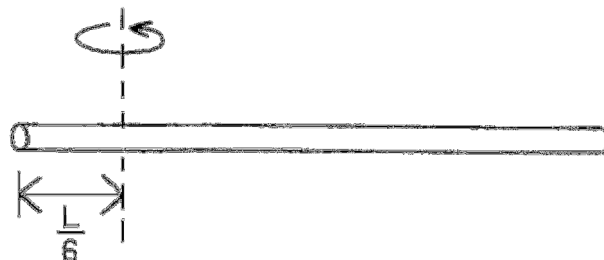

E. None of the above

5. Two solid uniform spheres roll down a ramp without slipping or sliding. Sphere #1 has twice the mass and half the diameter of sphere #2. If they are both released from the same height and at the same time, which one will arrive at the bottom of the ramp first?

- A. Sphere #1 will arrive first
 B. Sphere #2 will arrive first
 C. They will both arrive at the same time
 D. The result would depend upon the height of the ramp
 E. The result would depend upon the actual masses and diameters of the spheres

6. A rock is thrown into the air. At the very top of its trajectory, the velocity of the rock is level with the ground and has a magnitude v . A person standing on the ground at point P observes the rock at angle θ above the horizon as shown. The angular momentum of the rock about the point P at the moment it's at the top of its trajectory has a magnitude given by

- A. mv
 B. $mvD \sin \theta$
 C. $mvD \cos \theta$
 D. $mvD \tan \theta$
 E. 0 (zero)

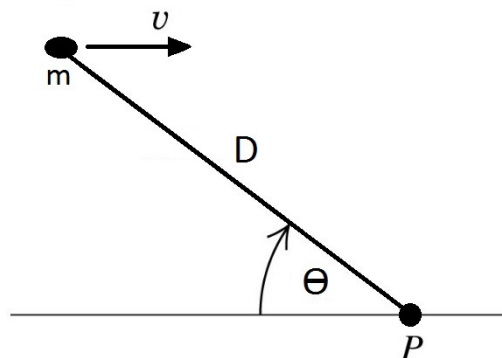

7. A wheel is spinning at 18 rad/s but is slowing with an angular acceleration that has a magnitude given by $(4.0 \text{ rad/s}^3) t$. The wheel will slow down to half its initial speed in a time of

- A. 1.5 s
- B. 2.1 s
- C. 2.3 s
- D. 3.0 s
- E. 4.5 s

8. A uniform rod of mass m and length L swings downward, pivoting about a point at the top of the rod. Which of the following is a true statement as the rod swings freely downward?

- A. The angular momentum of the rod about the pivot is conserved.
- B. The rotational kinetic energy of the rod is conserved.
- C. The rod swings down with a constant angular velocity.
- D. The rod swings down with a constant angular acceleration.
- E. None of the above.



9. Consider a uniform solid sphere of radius R and mass M rolling without slipping or sliding. Which form of kinetic energy is larger, translational (linear) or rotational?

- A. Its translational kinetic energy is larger than its rotational kinetic energy.
- B. Its rotational kinetic energy is larger than its translational kinetic energy.
- C. Both forms of energy are equal.
- D. You need to know the actual mass and radius of the sphere to determine this.
- E. The answer depends upon whether the ground is level or sloped, and by the degree of the slope.

10. Which of the following is a true statement?

- A. The moment of inertia of an object is the same for any axis passing through the center of mass of the object.
- B. The moment of inertia of an object is smallest for some axis passing through the center of mass of the object.
- C. An object with a non-uniform mass density may have more than one center of mass.
- D. The center of mass of an object is always inside the surface of the object.
- E. None of the above.

11. A student stands upon a freely-rotating platform with some initial angular speed, holding weights in both hands. The student then pulls the weights inwards. Which of the following is a true statement concerning the student and the weights?

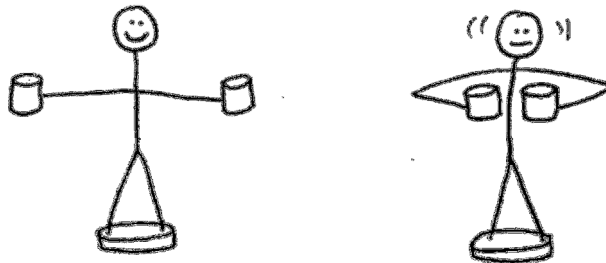

- A. The moment of inertia increases, the angular speed decreases and the rotational kinetic energy stays the same.
- B. The moment of inertia decreases, the angular speed increases and the rotational kinetic energy stays the same.
- C. The moment of inertia decreases, the angular speed increases and the rotational kinetic energy increases.
- D. The moment of inertia increases, the angular speed increases and the rotational kinetic energy decreases.
- E. None of the above.

12. The vector torque about the origin due to a force $\vec{F} = (1N)\hat{i} + (-3N)\hat{j}$ acting at the point $\vec{R} = (2m)\hat{i}$ would be

A. $\vec{\tau} = (2N \cdot m)\hat{k}$

B. $\vec{\tau} = (-6N \cdot m)\hat{k}$

C. $\vec{\tau} = (2N \cdot m)\hat{i}$

D. $\vec{\tau} = (6N \cdot m)\hat{k}$

E. $\vec{\tau} = \vec{0} \text{ N}\cdot\text{m}$

13. Two disks are mounted on low-friction bearings on a common shaft. The bottom disk has a rotational inertia I and is spinning with angular velocity ω . The top disk has rotational inertia $2I$ and is initially at rest as shown. The top disk is dropped onto the bottom disk along the shaft. They couple together and have a final common angular velocity of:

A. $\omega/3$

B. $\omega/\sqrt{3}$

C. $\omega/2$

D. $\omega/\sqrt{2}$

E. $2\omega/3$

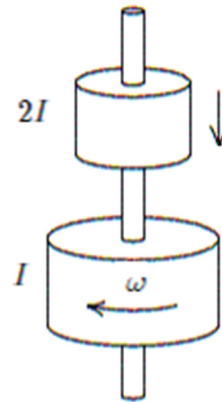

THE FOLLOWING PAGES GIVES FOUR EXAMPLES OF EXAM-
APPROPRIATE “LONG PROBLEMS” WHERE PARTIAL CREDIT IS
ALLOWED.

**THE ACTUAL EXAM WILL ONLY HAVE THREE LONG
PROBLEMS, WORTH ROUGHLY 20 POINTS EACH.**

For all long problems, you must show all work completely, legibly and in
logical order, starting with basic concepts.

Long problem Example 1:

A long uniform horizontal rod of total length 10.0 m and total mass 150 kg is attached to a wall by a hinge (pivot). It is supported by a wire attached at 7.00 m from the hinge. The wire makes an angle of 65° with the ceiling as shown.

The maximum tension allowed in the wire before it will break is 2016 N. You want to glue a block of mass 60.0 kg on the rod as far away from the hinge as possible.

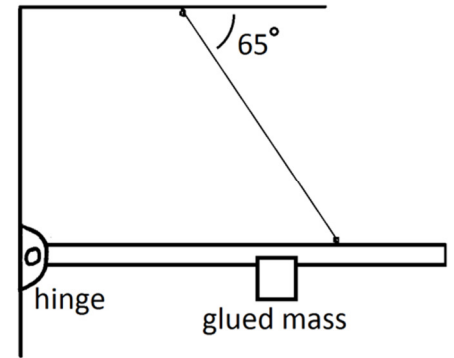

- a) Calculate the maximum distance away from the hinge that you can glue the block.

- b) When the block is in this maximum position, calculate the net force acting on the rod by the hinge. Leave the answer in unit vector (Cartesian) components.

Long problem Example 2:

A modified Atwood's machine consists of a block of mass m sliding on a rough table with kinetic friction coefficient 0.5. A hanging mass $3m$ pulls it by a massless string. The string passes over a pulley of mass $2m$. The pulley is a uniform disk of radius R . There is no slipping or sliding of the string over the pulley.

It is required to draw all relevant free body diagrams for the two masses and the pulley.

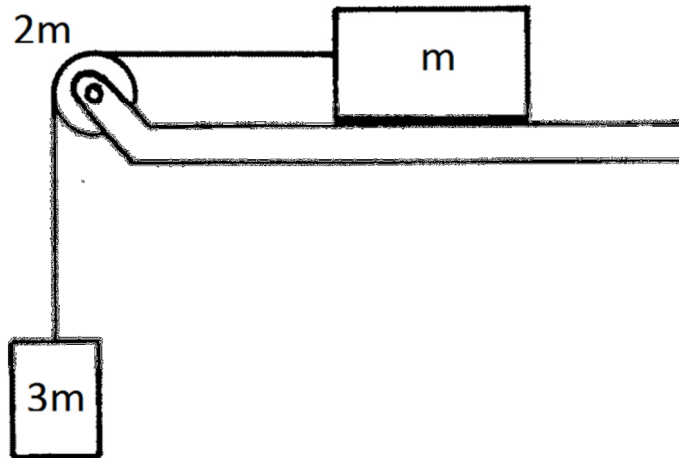

- a) Find the acceleration of the system when released from rest, as a multiple of the gravitational acceleration g .

(Continued next page →)

b) Find the tension on the vertical part of the string as a multiple of mg .

c) Find the tension on the horizontal part of the string as a multiple of mg .

Long problem Example 3:

A long thin rod of total length 4.00 m is pivoted 1.00 m from the top end. It is hung vertically and initially at rest as shown. The rod has a non-linear mass density given by $\lambda = (3 + 15x^2)$ kg/m, where $x = 0$ is at the pivot. A small piece of putty of mass 0.200 kg is shot horizontally into the lower end of the rod, striking it with a speed of 20.0 m/s. The putty sticks to the rod.

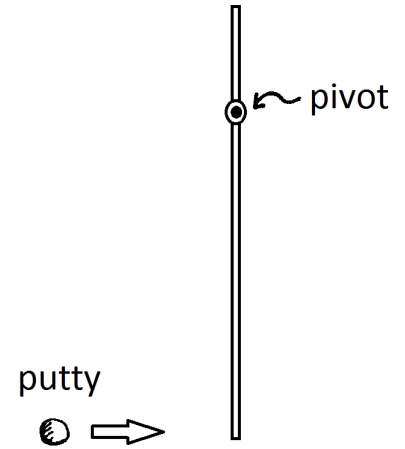

a) Calculate the moment of inertia I of the stick about the pivot.

b) Calculate the angular velocity ω of the stick the instant after the putty strikes and sticks to it.

c) If you were asked to find the maximum angle that the rod/putty combination would make with the vertical after the collision, explain in words how you would solve this problem. Do not actually solve. Maximum 3 sentences.

Long problem Example 4:

A uniform solid marble of mass $m = 0.020$ kg and diameter 0.010 m rolls without sliding down a symmetric steel bowl, starting from rest at point A, at the top of the left side. The top of each side is a distance $h = 0.15$ m above the bottom of the bowl. The left half of the bowl is rough enough to cause the marble to roll without slipping, but the right half is frictionless because it is coated with oil. Assume that there is no air resistance and no loss of energy due to kinetic friction in this problem.

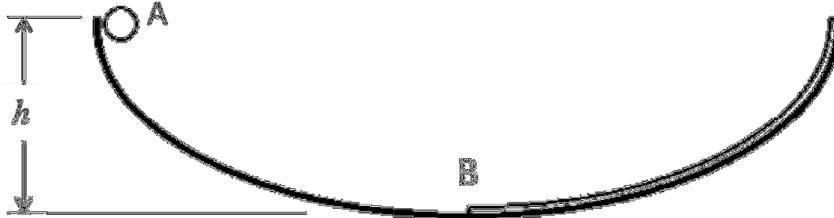

- a) Use energy techniques to determine the translational speed v of the center of mass of the marble when it is at point B at the bottom of the bowl.
- b) The transition from a rough to a smooth surface just after point B changes the marble's motion. Its rotational motion and translational motion are no longer constrained to change together. However both motions will still continue on into the right side of the bowl where there is no friction to stop either one. Use energy techniques to determine the maximum height y_{\max} that the marble reaches on the right side of the bowl.