

PHYS 211/211A
Exam #1 Sample Questions
University Physics I/IA

Part 1: Short Answer

You will have thirteen questions in this portion, worth 3 points each. You will **not** earn partial credit for these questions.

You will enter your answers into ExpertTA for these short answer questions. What you enter there is what is graded, and no work needs to be shown.

Here are many example short answer questions:

1. A ball is tossed at a 30° angle from the ground. At the instant when the ball is at its maximum height, select all of the true statements:

The acceleration of the ball is zero

The velocity of the ball is zero

The acceleration of the ball is downwards

The velocity of the ball is downwards

The velocity of the ball is perpendicular to the acceleration of the ball

1) At the maximum height, $v_y = 0$, and \vec{a} points straight down as always due to gravity. Since $v_x \neq 0$, $\vec{v} \perp \vec{a}$.

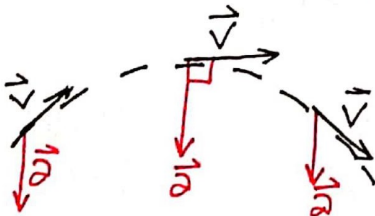

2. A car accelerates from rest on a straight road. A short time later, the car decelerates to a stop and then returns to its original position in a similar manner, by speeding up and then slowing to a stop. Which of the following coordinate versus time graphs best describes the motion?

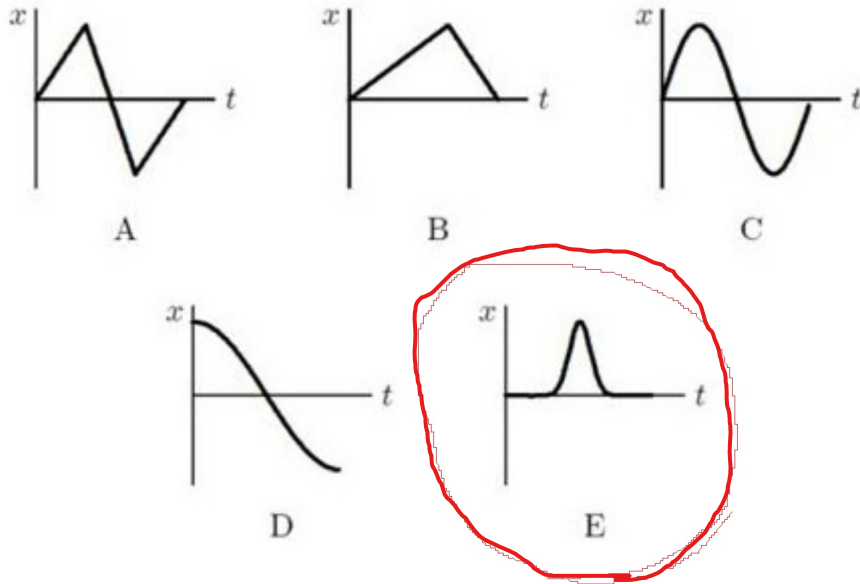

2) Because the car never goes behind its initial position, we can narrow our choices to B or E. Because the car accelerates, we know x vs. t won't look like straight lines. That leaves us with E.

3. Consider two blocks attached by a rope as shown. Ignore friction. The 9 kg is being pulled to the right by a rope, causing both blocks to accelerate to the right. The tension in the right rope is T_2 . The tension in the joining rope between the blocks is T_1 . How does T_1 compare to T_2 ?

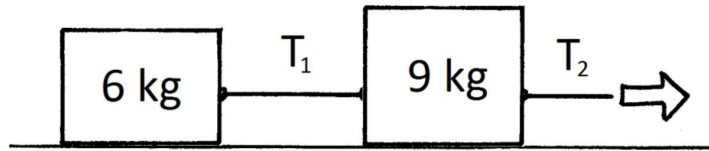

A. $T_1 < T_2$

B. $T_1 = T_2$

C. $T_1 > T_2$

D. require the magnitude of the pulling force to answer this

E. none of the above

3) For the 9 kg block:

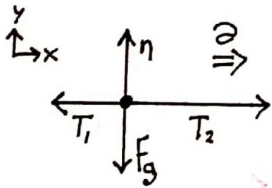

Because the block is accelerating to the right, \vec{F}_{net} must point to the right. $T_1 < T_2$.

4. A student of mass m is standing on a scale in an elevator that is near the surface of the Earth. The elevator is moving downward and slowing down with an acceleration of magnitude $g/4$. What weight does the scale read?

4) Heading downward but slowing down \Rightarrow accelerating upward.

\hat{z}_x \uparrow n
 $a \uparrow$ \downarrow F_g

$$F_{\text{net}}^y = ma_y$$
$$n - mg = +m\left(\frac{g}{4}\right)$$
$$n = \frac{5}{4}mg$$

5. In the same situation as the previous problem, where a student is standing on a scale in an elevator that is moving downward and slowing down, which of the following statements is true:
- A. The force of the scale on the student is greater in magnitude than the force of the student on the scale.
 - B. The force of the scale on the student is equal in magnitude to the force of the student on the scale.
 - C. The force of the scale on the student is lesser in magnitude than the force of the student on the scale.
 - D. There is not enough information to determine whether any of the above answers is correct.

5) By Newton's 3rd Law, the magnitude of the normal force exerted by the scale on the student is equal to that of the normal force exerted by the student on the scale.

6. The position of an object moving on a 2 dimensional plane is given by:

$$\mathbf{r}(t) = 18t \hat{i} - 2t^3 \hat{j},$$

where the position is measured in meters. What is the **speed** of the object at $t = 2$ seconds?

6) First, we take a time derivative to find the velocity.

$$\vec{v}(t) = \frac{d}{dt} \vec{r}(t) = \frac{d}{dt} \left(18 \frac{m}{s} t \hat{i} - 2 \frac{m}{s^3} t^3 \hat{j} \right) = 18 \frac{m}{s} \hat{i} - 6 \frac{m}{s^3} t^2 \hat{j}$$

The speed is the magnitude of the velocity vector.

$$|\vec{v}(t)| = \sqrt{v_x^2 + v_y^2} = \sqrt{\left(324 \frac{m^2}{s^2} \right) + \left(36 \frac{m^2}{s^6} t^4 \right)}$$

$$|\vec{v}(2s)| = 30 \text{ m/s}$$

7. A toy racing car moves with constant speed around the circle shown below. When it is at the point A its coordinates are $x = 0$, $y = 3 \text{ m}$ and its velocity is $(6 \text{ m/s}) \hat{i}$. When it is at the point B its velocity and acceleration are:

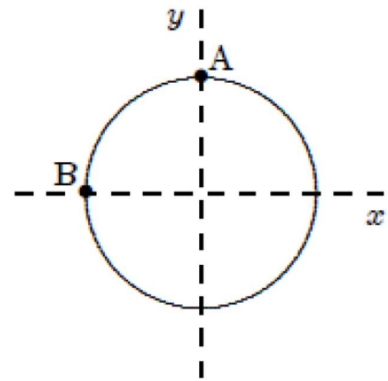

- A. $(6 \text{ m/s}) \hat{j}$ and $(12 \text{ m/s}^2) \hat{i}$ respectively
 B. $(6 \text{ m/s}) \hat{i}$ and $(-12 \text{ m/s}^2) \hat{i}$ respectively
 C. $(-6 \text{ m/s}) \hat{j}$ and $(12 \text{ m/s}^2) \hat{i}$ respectively
 D. $(6 \text{ m/s}) \hat{i}$ and $(2 \text{ m/s}^2) \hat{j}$ respectively
 E. $(6 \text{ m/s}) \hat{j}$ and $\vec{0}$ respectively

7) Acceleration points towards the center of the circle, and its magnitude obeys $a = \frac{v^2}{r} \Rightarrow \vec{a}_B = 12 \frac{\text{m}}{\text{s}^2} \hat{i}$.
 The speed is constant, and \vec{v} points tangent to the circle $\Rightarrow \vec{v}_B = 6 \frac{\text{m}}{\text{s}} \hat{j}$
 ($+\hat{j}$ because it's traveling clockwise).

8. A block of mass 20.0 kg is initially sitting at rest on level ground. A person then pushes on the block with a horizontal force P . The coefficient of kinetic friction between the block and the ground is 0.200 and the coefficient of static friction is 0.300. What is the minimum force P that the person must push with in order to start the box moving?

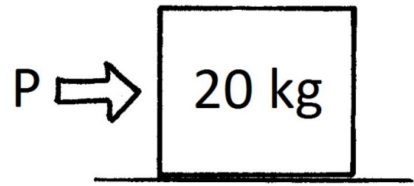

8) The minimum applied force to move the block just barely overcomes the maximum force of static friction, $f_s^{\max} = \mu_s n$. Because the block is resting on level ground w/ no forces in the y -direction besides \vec{n} and \vec{F}_g , n must be equal to mg .

$$P = f_s^{\max} = \mu_s n = \mu_s mg = \boxed{58.9 \text{ N}}$$

9. A stone is thrown directly upward from the surface of the Earth with an initial speed v_0 . Ignore air resistance. The total time of flight, from when it's initially thrown straight up until it hits the ground, is:

9) We'll use a 1D kinematic equation, setting y_0 and $y(t_{\text{flight}})$ both equal to zero.

$$y(t) = y_0 + v_{0y}t + \frac{1}{2}a_y t^2$$

$$0 = 0 + v_0 t_{\text{flight}} - \frac{1}{2}g t_{\text{flight}}^2$$

$$\frac{1}{2}g t_{\text{flight}}^2 = v_0 t_{\text{flight}}$$

$$t_{\text{flight}} = \frac{2v_0}{g}$$

10. A crate first slides up an inclined ramp ($0^\circ < \theta < 90^\circ$), momentarily comes to rest, and then slides back down the ramp. There is friction between the crate and the ramp. Which of the following statements is true?

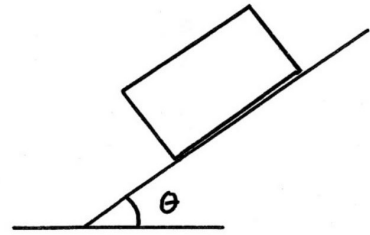

- A. The magnitude of the block's acceleration is greatest as it travels up the ramp.
 B. The magnitude of the block's acceleration is the same going up or down the ramp.
 C. The magnitude of the block's acceleration is greatest as it travels down the ramp.
 D. The static coefficient of friction is greater than $\tan \theta$.
 E. There is not enough information given to determine any of these options.

10) Because the block is sliding, we can't draw any conclusions about the static friction. What we do know is that the force of kinetic friction always opposes the motion.

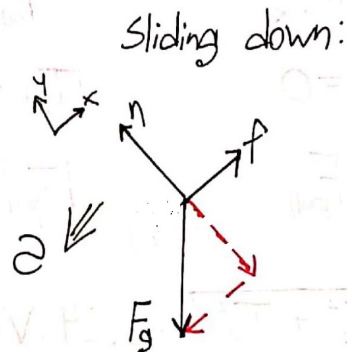
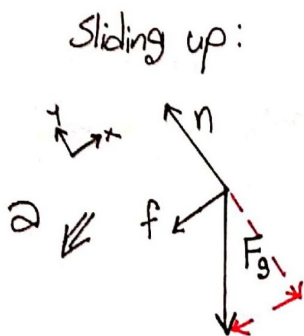

The magnitude of the acceleration is greater when the block is on the way up, because the magnitude of the net force is greater when the block is on the way up — F_g and f are working together, rather than against each other (see the components of F_g , added to the diagram in red).

11. Vectors \vec{A} and \vec{B} are shown in the figure, where \vec{A} is 42.0° from the y axis and \vec{B} is 31.0° below the negative x axis. The magnitude of vector \vec{A} is 16.00 m and the magnitude of vector \vec{B} is 7.00 m. Vector \vec{C} is given by $\vec{C} = \vec{A} + \vec{B}$. What is the component of the vector \vec{C} along the \hat{i} direction?

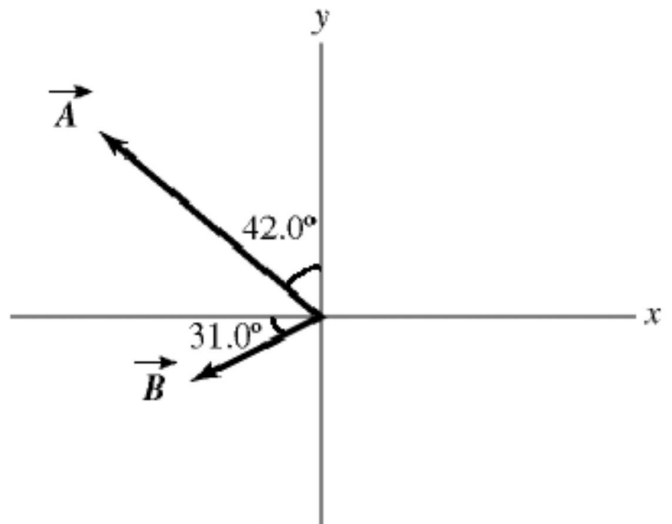

11) Vectors add by components.

$$\vec{C} = \vec{A} + \vec{B}$$

$$C_x = A_x + B_x$$

$$C_x = -|\vec{A}|\sin(42^\circ) - |\vec{B}|\cos(31^\circ)$$

$$C_x = -16.7 \text{ m}$$

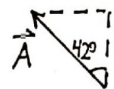

$$\vec{A} = -|\vec{A}|\sin 42^\circ \hat{i} + |\vec{A}|\cos 42^\circ \hat{j}$$

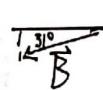

$$\vec{B} = -|\vec{B}|\cos 31^\circ \hat{i} - |\vec{B}|\sin 31^\circ \hat{j}$$

Adjacent leg \Rightarrow cos

Opposite leg \Rightarrow sin

And be careful w/ the signs.

(Which way does each vector point?)

12. A pendulum bob with a weight of 1 N is held at an angle θ from the vertical by a 2 N horizontal force F as shown. What is the tension in the string supporting the pendulum bob?

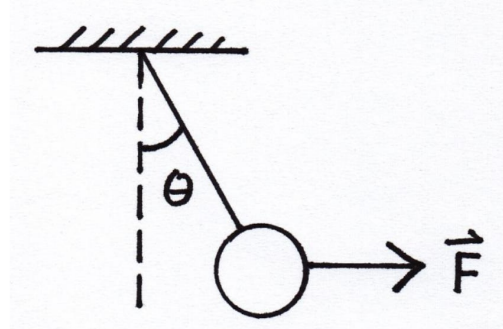

12) We need to use N2L to find T . θ is also unknown, but applying N2L to both x and y will get us the two equations we need!

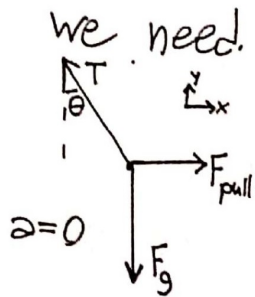

$$F_{\text{net}}^x = m a_x$$

$$F_{\text{net}}^y = m a_y$$

$$F_{\text{pull}} - |T_x| = 0$$

$$|T_y| - F_g = 0$$

$$|T_x| = F_{\text{pull}}$$

$$|T_y| = F_g$$

$$T = \sqrt{T_x^2 + T_y^2} = 2.24 \text{ N}$$

To check our result, we can make sure both components give us consistent answers for the angle.

$$\sin \theta = \frac{|T_x|}{T} = \frac{2 \text{ N}}{2.24 \text{ N}}$$

$$\cos \theta = \frac{|T_y|}{T} = \frac{1 \text{ N}}{2.24 \text{ N}}$$

$$\theta = 63.4^\circ$$

$$\theta = 63.4^\circ$$

Checks out!

13. A UFO moves in one dimension according to the equation $v(t) = 4.00 - 9.00t^2$ for $t \geq 0$. What are the SI units of 9.00 in this equation?

13) This is a job for dimensional analysis. For velocity, every term needs units of m/s.

$$[9.00][t^2] = [v] \quad ([A] \text{ means "A has units of...")$$

$$[9.00] = \frac{[v]}{[t^2]}$$

$$[9.00] = \frac{\text{m}}{\text{s}^2} = \boxed{\text{m/s}^2}$$

Sure enough, if we multiply $9.00 \frac{\text{m}}{\text{s}^2}$ by t^2 , we get a term with the required units of m/s.

14. A UFO moves in one dimension according to the equation $a(t) = 18.00t^2$ for $t \geq 0$. At what time is the UFO momentarily at rest?

14) The UFO is instantaneously at rest for $t = t_{\text{rest}}$ such that $\vec{v}(t_{\text{rest}}) = 0$.
First we need to time-integrate $a(t)$ to find $v(t)$.

$$v(t) = \int a(t) dt = \int 18.00 \frac{\text{m}}{\text{s}^4} t^2 dt = 6.00 \frac{\text{m}}{\text{s}^4} t^3 + V_0$$

The integration constant is identified w/ our unknown initial velocity.
Now we solve for t_{rest}

$$0 = 6.00 \frac{\text{m}}{\text{s}^4} t_{\text{rest}}^3 + V_0$$

$$t_{\text{rest}} = -\left(\frac{V_0}{6.00 \frac{\text{m}}{\text{s}^4}}\right)^{1/3}$$

Note that we can conclude that V_0 must be ≤ 0 , since we're told that t must be ≥ 0 .

15. A particle is displaced by $\Delta\vec{r} = (30.0 \text{ m})\hat{i} - (10.0 \text{ m})\hat{j}$ while being acted upon by a constant force $\vec{F} = (1.00 \text{ N})\hat{i} - (2.00 \text{ N})\hat{j} - (3.00 \text{ N})\hat{k}$. The work done on the particle by this force is

15) Since the force is constant, we don't need to worry about integrating.

$$W = \vec{F} \cdot \Delta\vec{r} = F_x \Delta r_x + F_y \Delta r_y + F_z \Delta r_z = 30.0 \text{ J} + 20.0 \text{ J} + 0 \text{ J}$$

$$W = 50.0 \text{ J}$$

16. A force acting upon a particle is called conservative if

- A. it obeys Newton's Second Law
- B. it obeys Newton's Third Law
- C. its work equals the change in the kinetic energy of the particle
- D. its work is independent of the path between any two points
- E. it is not a frictional force

16) A conservative force does path-independent work. One important consequence of this is that if the particle returns to where it started, the net work done by a conservative force is zero — you get back whatever you put in (on this point, is friction a conservative force?).

17. An object moves in a circular path at constant speed. The work done by the centripetal (radial) force is zero because

- A. the magnitude of the acceleration is zero
- B. the average force for each revolution is zero
- C. there is no friction
- D. the displacement for each revolution is zero
- E. the centripetal (radial) force is perpendicular to the velocity

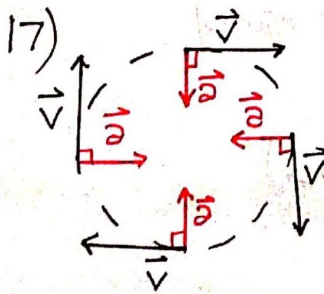

For circular motion at constant speed, \vec{a} always points straight towards the center. As a result \vec{a} is always \perp to \vec{v} , and the angle between \vec{F}_{net} and the displacement is always 90° . $\cos 90^\circ = 0$, so no work is done by the radial force.

18. An object moving along the x-axis is acted on by a force F_x that varies with position as shown. How much work is done by this force on the object as it moves from $x = 2.00$ m to $x = 8.00$ m?

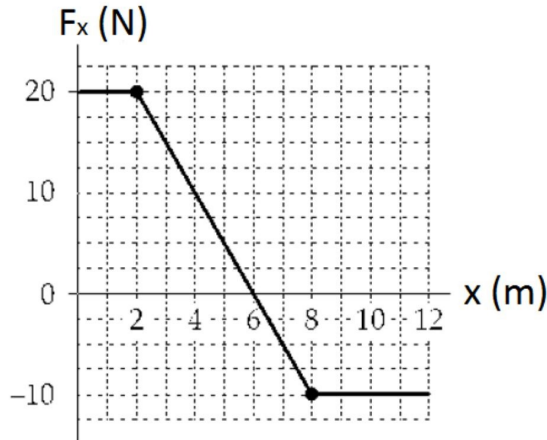

18) The Work done by the force is computed by finding the area under the F_x vs. x curve.

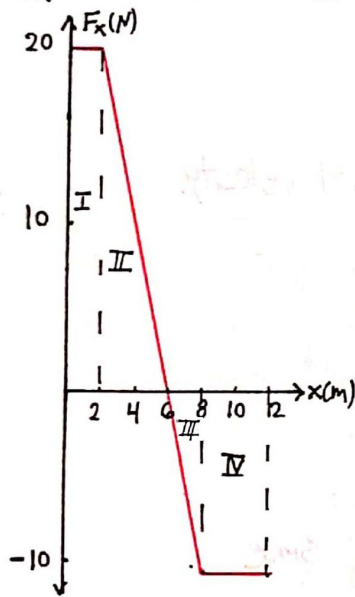

From $x = 2.00$ m to $x = 8.00$ m, we're in what I've called "regions" II and III.

$$W = W_{\text{II}} + W_{\text{III}}$$

$$= \frac{1}{2}(4\text{m})(20\text{N}) + \frac{1}{2}(2\text{m})(10\text{N})$$

$$W = 30\text{J}$$

19. The potential energy of a body of mass m is given by $U = \frac{1}{2}kx^2 + mgx + 5$. The corresponding force on the mass is:

19) $F_x = -\frac{\partial}{\partial x} U$ To find force in x -direction, take negative derivative with respect to x .

$$\vec{F} = -\frac{\partial}{\partial x} \left(\frac{1}{2}kx^2 + mgx + 5J \right) \hat{i}$$

$$\vec{F} = (-kx - mg) \hat{i}$$

20. A 5.00 kg object is acted on by a net force in the x-direction that does 600 J of work as it moves a distance of 2.00 m in 6.00 s. The average power being applied to the object is:

$$20) P_{\text{avg}} = \frac{W}{\Delta t} = \frac{600\text{J}}{6.00\text{s}} = 100\text{W}$$

(that's a W for "watts," unlike the W for "work" in the formula).

21. A block is given an initial speed v and then moves across a level surface with coefficient of kinetic friction μ_k . How far does it travel across the rough surface before stopping?

21) Energy conservation will work, as long as we account for the internal energy added by friction.

$$U_i + KE_i = U_f + KE_f + \Delta U_{int}$$

$$0 + \frac{1}{2}mv^2 = 0 + 0 + (-W_f) = -(-\mu_k n d)$$

level surface,
so $n = mg$.

$$= \frac{1}{2}mv^2 = -(-\mu_k mg d)$$

$$d = \frac{v^2}{2\mu_k g}$$

22. A ball of unknown mass is thrown off of a building of height h at some unknown angle. Its speed just before striking the level ground below is v_f . What is the initial speed of the ball, ignoring air resistance?

22) Not enough information to use kinematics, but energy conservation will get the job done.

$$U_{gi} + KE_i = U_{gf} + KE_f$$

$$mgh + \frac{1}{2}mv_i^2 = 0 + \frac{1}{2}mv_f^2$$

$$\frac{1}{2}mv_i^2 = -mgh + \frac{1}{2}mv_f^2$$

$$v_i = \sqrt{v_f^2 - 2gh}$$

23. A ball of mass m is attached to a string of length L . It is made to rotate as a conical pendulum, making an angle of θ with the vertical, as shown. What is the speed of the ball?

23) We know that the speed of the ball will be related to the magnitude of the radial force by

$$F_{\text{rad}} = \frac{mv^2}{r}$$

$$v = \sqrt{\frac{r F_{\text{rad}}}{m}}$$

$$v = \sqrt{\frac{L F_r \sin \theta}{m}}$$

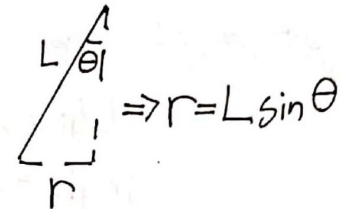

Now we need to find F_{rad} . FBD time.

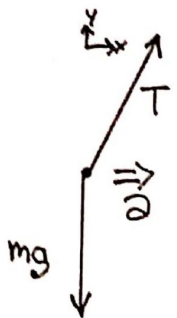

Our center-pointing force is contributed by the x -component of our Tension.

$$F_r = T_x = T \sin \theta.$$

Now we just need to find T . To do so, we'll use the fact that there's no acceleration in the y -direction.

$$F_{\text{net}}^y = m a_y$$

$$T_y - mg = 0$$

$$T \cos \theta - mg = 0$$

$$T = \frac{mg}{\cos \theta} \Rightarrow F_r = mg \tan \theta$$

Now we plug everything in to find v :

$$v = \sqrt{\frac{L F_r \sin \theta}{m}} = \sqrt{\frac{L mg \tan \theta \sin \theta}{m}} = \sqrt{gL \tan \theta \sin \theta} = v$$

24. A ball of mass m , at one end of a string of length L , rotates in a vertical circle just barely fast enough to prevent the string from going slack at the top of the circle. The speed of the ball at the bottom of the circle is:

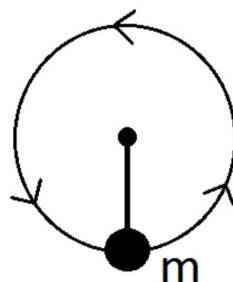

24) If we knew the speed at the top, we could find the speed at the bottom using energy conservation.

$$U_{g \text{ top}} + KE_{\text{top}} = U_{g \text{ bot}} + KE_{\text{bot}}$$

$$mg(2L) + \frac{1}{2}mV_{\text{top}}^2 = 0 + \frac{1}{2}mV_{\text{bot}}^2$$

$$V_{\text{bot}} = \sqrt{V_{\text{top}}^2 + 4gL}$$

To find V_{top} , we consider $N2L$ as applied to circular motion.

At top:

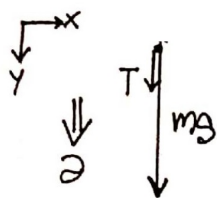

$$F_r = \frac{mV_{\text{top}}^2}{L}$$

$$T_{\text{top}} + mg = \frac{mV_{\text{top}}^2}{L}$$

$$V_{\text{top}} = \sqrt{\frac{L}{m} T_{\text{top}} + gL}$$

Since the ball just barely makes it around the loop,

$$T_{\text{top}} \rightarrow 0 \text{ and } V_{\text{top}} = \sqrt{gL}$$

We can finally find V_{bot} .

$$V_{\text{bot}} = \sqrt{V_{\text{top}}^2 + 4gL}$$

$$V_{\text{bot}} = \sqrt{5gL}$$

25. Consider the potential energy diagram shown. Which of the points has a force that is directed towards the left (along the negative x axis)?

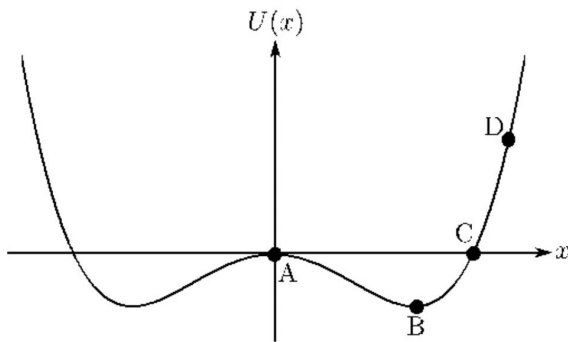

- A. Point A only
- B. Point B only
- C. Point C only
- D. Point D only
- E. Both points C and D

25) $F_x = -\frac{\partial}{\partial x} U(x)$. When the slope of $U(x)$ is positive, the force points in the $-\hat{x}$ direction.

26. A crate of mass 15 kg is on a level floor that has a coefficient of kinetic friction of 0.230. A person is pushing the crate across the floor by applying a force parallel to the ground. They are getting tired as they push so the force they exert is given by $F(x) = (80 \text{ N}) - (10 \text{ N/m})x$, where $x = 0$ is the starting position. They push the crate from rest a total of 5.0 m. **What is the speed of the block at 5.0 m?**

26) We'll use the work-kinetic energy theorem.

$$W_{\text{net}} = \Delta KE$$

$$W_{\text{person}} + W_f = KE_f - KE_i$$

$$\int_{0\text{m}}^{5\text{m}} [80\text{N} - 10\frac{\text{N}}{\text{m}}x] dx - \int_{0\text{m}}^{5\text{m}} \mu_k mg dx = \frac{1}{2}mV_f^2 - 0$$

starts from rest

negative, because friction always acts opposite the motion

$$[80\text{N}x - 5\frac{\text{N}}{\text{m}}x^2] \Big|_{x=0\text{m}}^{5\text{m}} - \mu_k mgx \Big|_{x=0\text{m}}^{5\text{m}} = \frac{1}{2}mV_f^2$$

$$275 \text{ J} - 33.81 \text{ J} = \frac{1}{2}(15\text{kg})V_f^2$$

$$V_f = 5.67 \text{ m/s}$$

Solutions to all example long problems are at the end of this document.

Part 2: Long Problems

The following pages give five “exam-appropriate” long problems, where your work is shown and partial credit is given.

The ACTUAL exam will only have THREE long problems, each worth 20 points.

For all long problems, you must show all work completely, legibly and in logical order, starting with basic concepts. You will upload a single pdf of your work for all three problems (like you do with video notes) and upload them to a myCourses dropbox.

Long problem Example 1:

Chuck throws a stone from the edge of the roof of a building with an initial speed of 25.0 m/s at an angle 35.0° below the horizontal, as shown in the figure. Chuck releases the stone 90.0 m above the ground. Assume that the ground is perfectly horizontal and air resistance is negligible.

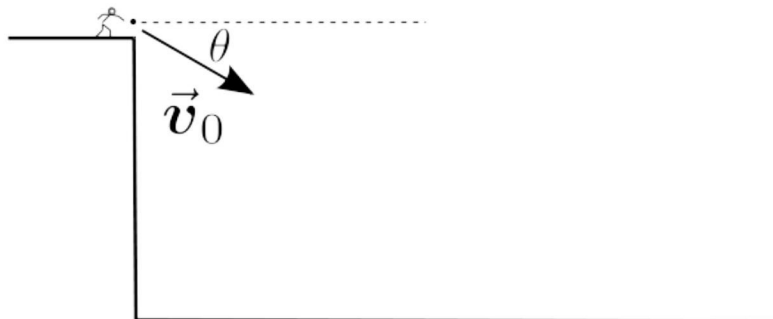

- Sketch the stone's trajectory in the figure above.
- Calculate the horizontal distance from the base of the building to where the stone strikes the ground.
- Calculate the speed of the stone the instant before it strikes the ground **and** the impact angle. Indicate the angle you have calculated clearly on the diagram.

Reminder: After completing the three long problems, you will upload a pdf of your written work to the myCourses “Exam 1 Long Problems” dropbox. What is uploaded there is what is graded for those problems. There is nothing that needs to be entered on ExpertTA for this problem.

Long problem Example 2:

A modified Atwood's machine has a mass $2m$ **initially sliding to the left** on a horizontal table as shown, attached to a dangling mass m . The coefficient of kinetic friction between sliding mass and the table is μ_k .

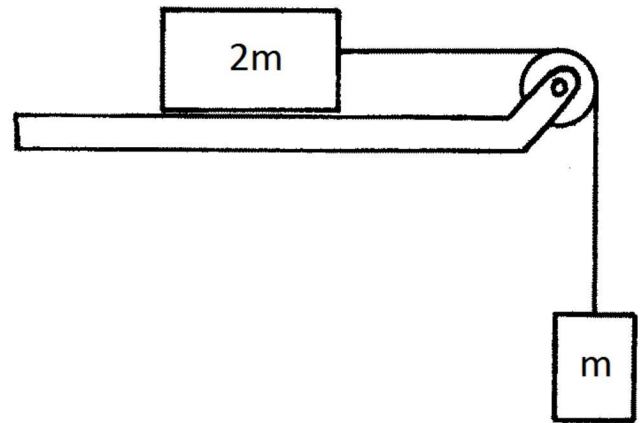

- (a) Write an expression for the magnitude of the initial acceleration of the system and the tension in the cable in terms of the given parameters $\{m, \mu_k, g\}$. Make sure to draw a Free-Body Diagram, either on the drawing or in the space below (it counts for points).
- (b) Say the initial speed of the $2m$ block was v_0 . How far does the $2m$ block travel before coming momentarily to rest?

Reminder: After completing the three long problems, you will upload a pdf of your written work to the myCourses "Exam 1 Long Problems" dropbox. What is uploaded there is what is graded for those problems. There is nothing that needs to be entered on ExpertTA for this problem.

Long problem Example 3:

A block of mass 2.00 kg starts from rest a distance 0.500 m from the top edge of a ramp as shown. It is pushed up the ramp by a 30.0 N force, F , acting parallel to the ground as shown. The ramp makes an angle of 40.0° with the horizontal, and the coefficient of kinetic friction between the block and ramp is 0.250 . When the block reaches the top of the ramp, the force F stops acting so that the block is only under the influence of gravity. The block is therefore launched from the top of the ramp at the same angle of the ramp, and it follows a parabolic trajectory in the air. Take the acceleration due to Earth's gravity to be 9.80 m/s².

How long does it take for the block to travel from the edge of the ramp (point A) to the top of its trajectory (point B)? Clearly show all work and steps to receive any credit.

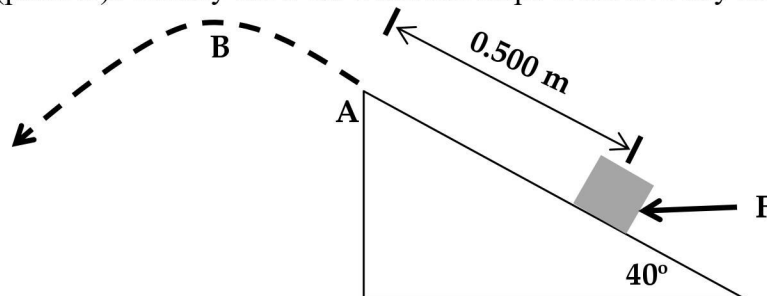

Reminder: After completing the three long problems, you will upload a pdf of your written work to the myCourses "Exam 1 Long Problems" dropbox. What is uploaded there is what is graded for those problems. There is nothing that needs to be entered on ExpertTA for this problem.

Long Problem Example 4:

A block of mass m starts from rest at the top of a frictionless hill of height H . It slides down the hill and then over another hill of height h as shown. The top of the second smaller hill can be modeled as part of a circle with radius h . If $H = 5h/4$, what is the normal force that the track exerts on the block when it is at the top of the second hill? Express your answer in terms of m and g . If any part of your solution involves a free-body diagram, it must be clearly shown.

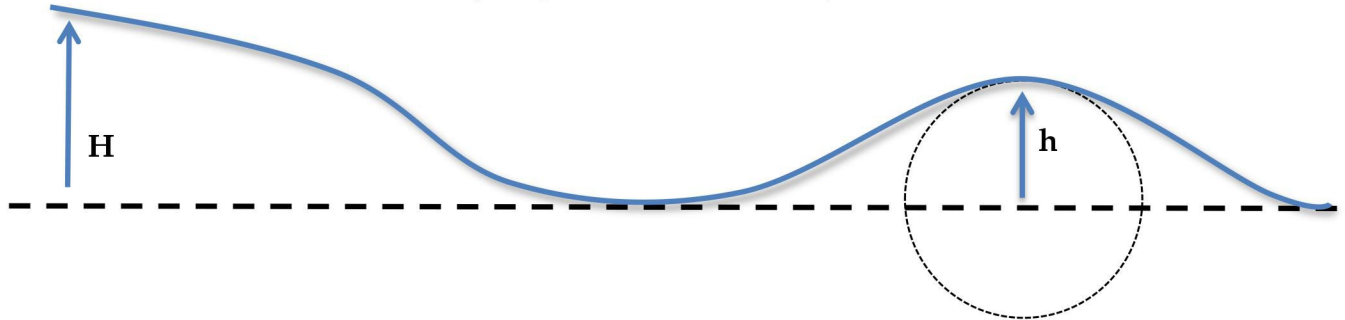

Reminder: After completing the three long problems, you will upload a pdf of your written work to the myCourses “Exam 1 Long Problems” dropbox. What is uploaded there is what is graded for those problems. There is nothing that needs to be entered on ExpertTA for this problem.

Long Problem Example 5:

A block of mass $m = 8.00$ kg moves with initial speed $v_0 = 6.00$ m/s along a track, as shown. The upper part of the track is a height $h = 10.0$ m above the lower part of the track. There is no friction between the block and the track until the block reaches the rough patch on the lower part of the track, at which point the coefficients of kinetic and static friction are $\mu_k = 0.250$ and $\mu_s = 0.350$ respectively. After traveling a distance $L = 16.0$ m over the rough patch, the block collides with a very long, ideal spring with spring constant k . The block compresses the spring by a maximum distance $d = 4.00$ m, with friction still acting upon the block.

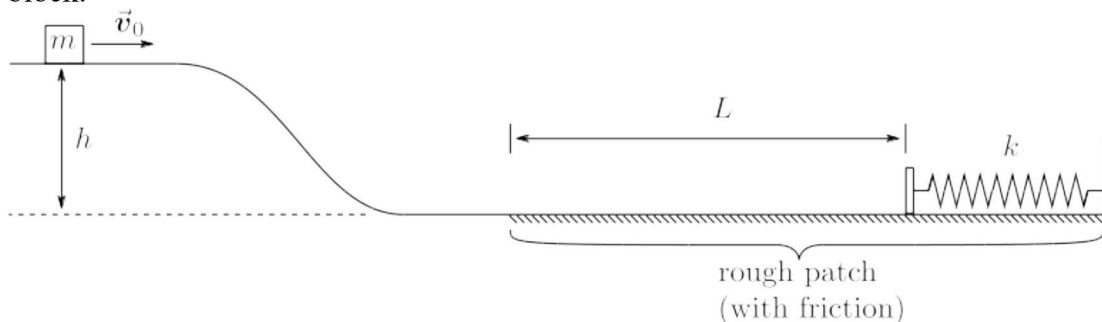

- Calculate the numerical value of the spring constant, with appropriate units.
- After the mass stops at the maximum spring compression, will it move again?

Reminder: After completing the three long problems, you will upload a pdf of your written work to the myCourses “Exam 1 Long Problems” dropbox. What is uploaded there is what is graded for those problems. There is nothing that needs to be entered on ExpertTA for this problem.

Example Long Problem #6

A container of mass $m = 3.00$ kg starts from rest at $x = 0$ on a frictionless level desktop. Then, a net force, $F(x)$, **that varies with position** is applied to the container from $x = 0.00$ to $x = 1.40$ m. The variable force $F(x)$ is given in Newtons by:

$$F(x) = Zx^4$$

Where x is the position in meters and Z is a positive constant. When the force stops acting, the container continues to slide along the frictionless desktop until it is launched off horizontally and falls under the influence of gravity to the level ground below. The container lands a horizontal distance $D = 0.937$ m from the edge of the desktop.

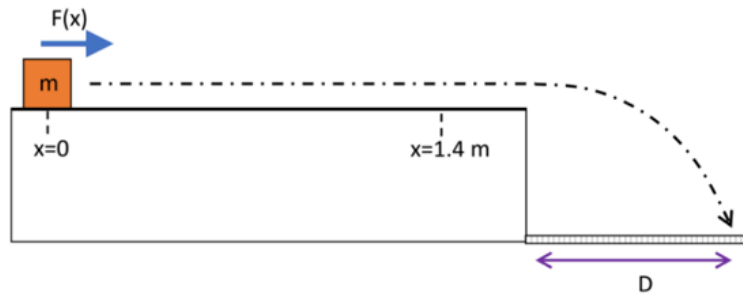

mtiraps@rit.edu 4N89-94-18-47-9797-25794

▶ ⚠ (a) (2 pts) What are the units of the constant Z ?

(b) (14 pts) Take the value of Z to be 4.00. Find the velocity of the container at the instant just before it strikes the ground. **Express the velocity in unit vector notation.** State all final numerical values to three significant figures and include units.

(c) (4 pts) Find the angle at which the container strikes the ground, given in degrees relative to the horizontal. Provide three significant figures.

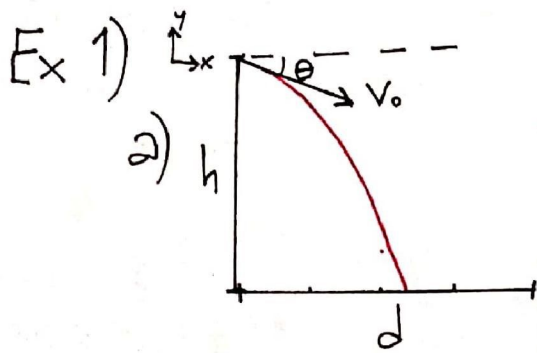

Constant acceleration in $-\hat{y}$ direction
 \Rightarrow parabola opening downward.

b) Don't know d or t . Need a system of two equations.

$$x(t) = x_0 + v_{0x}t + \frac{1}{2}a_x t^2 \quad y(t) = y_0 + v_{0y}t + \frac{1}{2}a_y t^2$$

$$d = 0 + v_0 \cos \theta t + 0 \quad 0 = h - v_0 \sin \theta t - \frac{1}{2}g t^2$$

$$t = \frac{d}{v_0 \cos \theta} \quad \text{Now plug this } t \text{ into our other equation and solve for } d.$$

$$0 = -\frac{1}{2}g t^2 - v_0 \sin \theta t + h$$

$$0 = \frac{-g}{2v_0^2 \cos^2 \theta} d^2 - \tan \theta d + h$$

Now we use the quadratic formula (or a solver) and take the positive root.

$$d = \frac{v_0^2 \cos^2 \theta}{g} \left(-\tan \theta + \sqrt{\tan^2 \theta + \frac{2gh}{v_0^2 \cos^2 \theta}} \right)$$

This expression looks messy, but I like it because we can check some limiting cases. What happens to d when v_0 goes to zero? When v_0 goes to infinity? Does d behave like you'd expect?

Plug the known numbers in, and we get

$$d = 52.8 \text{ m}$$

Ex 1c)

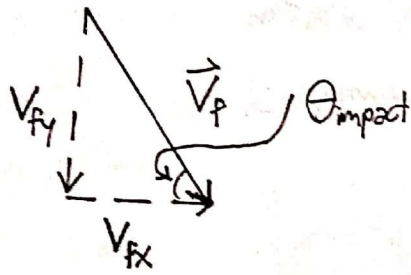

$$\tan \theta_{\text{impact}} = \frac{|V_{fy}|}{|V_{fx}|}$$

$$|\vec{V}_f| = \sqrt{V_{fx}^2 + V_{fy}^2}$$

We need V_{fx} and V_{fy} .

There's no acceleration in the x-direction, so $V_{fx} = V_{ox} = V_o \cos \theta$.

To find V_{fy} , we'll use kinematics.

$$V_{fy}^2 = V_{oy}^2 + 2a\Delta y$$

$$V_{fy}^2 = (-V_o \sin \theta)^2 + 2(-g)(-h)$$

$$V_{fy} = -\sqrt{V_o^2 \sin^2 \theta + 2gh}$$

(Negative root because the ball is headed downward.)

$$|\vec{V}_f| = \sqrt{V_{fx}^2 + V_{fy}^2} = 48.9 \text{ m/s}$$

$$\theta_{\text{impact}} = \tan^{-1} \left(\frac{|V_{fy}|}{|V_{fx}|} \right) = 65.2^\circ \text{ above the horizontal}$$

EX 2) We start with a FBD and then use N2L for each block to generate a system of two equations.

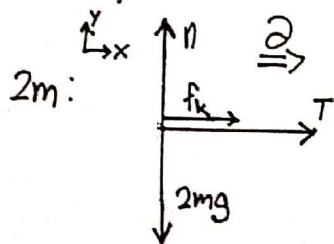

(Friction points right because the block is sliding to the left.)

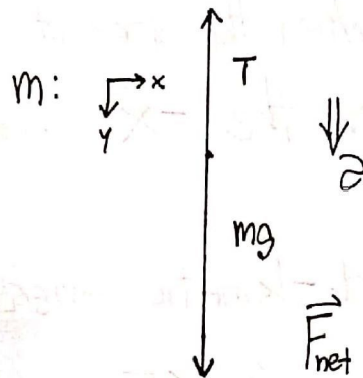

$$\vec{F}_{\text{net}} = m\vec{a}$$

$$-T + mg = +m\vec{a}$$

$$\vec{F}_{\text{net}} = m\vec{a}$$

$$+T + f_k = +2m\vec{a}$$

$$T + \mu_k n = 2m\vec{a}$$

$$T + \mu_k (2mg) = 2m\vec{a}$$

n is equal to mg this time because we have no other forces in the y -direction and are on a level surface.

Now we solve the system algebraically. I'll start by adding my two equations together to get rid of T , then solve for a .

$$T + 2\mu_k mg = 2m\vec{a}$$

$$-T + mg = m\vec{a}$$

$$0 + mg + 2\mu_k mg = 3m\vec{a}$$

$$\vec{a} = \frac{1}{3}g(1 + 2\mu_k)$$

Now I plug a back in to solve for T .

$$-T + mg = m\vec{a}$$

$$-T + mg = \frac{mg}{3}(1 + 2\mu_k)$$

$$T = mg - \frac{mg}{3} - \frac{2}{3}mg\mu_k$$

$$T = \frac{2}{3}mg(1 - \mu_k)$$

Double check this result by plugging it back into the equation from the mass on the table.

b) We have constant a , so we can use kinematics.

$$v_x^2 = v_{0x}^2 + 2a_x \Delta x$$

$$0 = v_0^2 + 2 \cdot \frac{1}{3}g(1 + 2\mu_k)\Delta x$$

$$\Delta x = \frac{-3v_0^2}{2g(1 + 2\mu_k)}$$

When the block is instantaneously at rest, $v_x = 0$.

The negative sign in my answer reflects that the block moves to the left, but I wouldn't mark you off for it here, since the question asks "how far" rather than "what is the displacement."

EX 3) First, we can use kinematics in the air, using the fact that $v_y = 0$ at the top of the arc:

$$v_y(t) = v_{0y} + at$$

$$0 = v_{0y} - gt$$

$$t = \frac{v_{0y}}{g} \quad (\text{taking } t=0 \text{ to be the time when the block leaves the ramp})$$

We just need to find v_{0y} , the y-component of the block's velocity at the top of the ramp. We can find the speed, v_0 , by using the work-kinetic energy theorem.

$$W_{\text{net}} = KE_{\text{top}} - KE_{\text{bottom}}$$

$$W_n + W_f + W_F + W_g = \frac{1}{2}mv_0^2 - 0 \Rightarrow v_0 = \sqrt{\frac{2}{m}(W_f + W_F + W_g + W_n)}$$

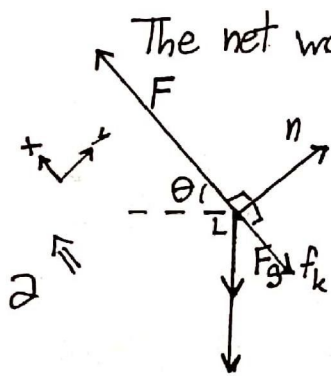

The net work is the sum of the work done by all forces.

$$\vec{F}_g = mg \quad \text{The angle between } \vec{F}_g \text{ and } \Delta\vec{r} \text{ is } \theta + 90^\circ$$

$$n = mg \cos \theta \quad \text{The angle between } \vec{n} \text{ and } \Delta\vec{r} \text{ is } 90^\circ$$

$$f_k = \mu_k n = \mu_k mg \cos \theta \quad \text{The angle between } \vec{f}_k \text{ and } \Delta\vec{r} \text{ is } 180^\circ$$

The applied \vec{F} is parallel to $\Delta\vec{r}$

$$W_f = \vec{F} \cdot \Delta\vec{r} = (0.25)(2.00 \text{ kg})(9.80 \text{ m/s}^2)(.500 \text{ m}) \cos 40^\circ \cdot \cos(180^\circ) = -1.88 \text{ J}$$

$$W_F = \vec{F} \cdot \Delta\vec{r} = (30.0 \text{ N})(.500 \text{ m}) \cos 0^\circ = 15.0 \text{ J}$$

$$W_g = (2.00 \text{ kg})(9.80 \text{ m/s}^2)(.500 \text{ m}) \cos(40^\circ + 90^\circ) = -6.30 \text{ J}$$

$$W_n = (2.00 \text{ kg})(9.80 \text{ m/s}^2)(.500 \text{ m}) \cos 40^\circ \cdot \cos 90^\circ = 0 \text{ J}$$

$v_0 = \sqrt{\frac{2}{m}(W_f + W_F + W_g + W_n)} = 2.61 \text{ m/s}$. We pick out the y-component, $v_{0y} = v_0 \sin \theta$, then plug our result back into t to find the time we wanted.

$$t = \frac{v_{0y}}{g} = 0.171 \text{ s}$$

EX 4) The normal force the block experiences at the top of h will depend on its speed.

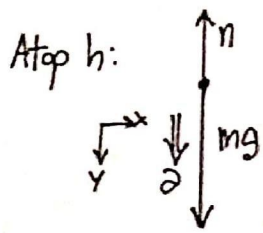

On a circular arc, we know that $F_{\text{rad}} = \frac{mv^2}{r}$. We calculate F_{rad} by adding all forces towards the center of the arc and subtracting all forces pointing radially outward.

$$+mg - n = \frac{mV_h^2}{h}$$

$$n = mg - \frac{mV_h^2}{h}$$

Now we need to find V_h , the speed at the top of the smaller hill. We'll do this by using energy conservation to connect the points when the mass is at the top of each hill.

$$U_{gH} + KE_H = U_{gh} + KE_h$$

$$mgH + \underset{\substack{\text{(starts from} \\ \text{rest)}}}{0} = mgh + \frac{1}{2}mV_h^2$$

$$mg\left(\frac{5}{4}h\right) - mgh = \frac{1}{2}mV_h^2$$

(recall that $H = \frac{5}{4}h$)

$$V_h^2 = \frac{2}{m} [mgh\left(\frac{5}{4} - 1\right)] = 2gh\left(\frac{1}{4}\right) = \frac{1}{2}gh$$

Now we can plug V_h^2 into our above expression for the normal force atop h .

$$n = mg - \frac{mV_h^2}{h} = mg - \frac{\frac{1}{2}mgh}{h}$$

$$n = \frac{1}{2}mg$$

EX 5) We'll use energy conservation, starting with when the block is at height h w/ speed v_0 , and ending when the spring is at its maximum compression d and the block is instantaneously at rest.

a)

$$U_{gi} + U_{ki} + KE_i = U_{gf} + U_{kf} + KE_f + \Delta U_{int}$$

$$mgh + 0 + \frac{1}{2}mv_0^2 = 0 + \frac{1}{2}kd^2 + 0 + f(L+d)$$

don't forget the $+d$.
the diagram shows us that there's still friction under the spring this time.

$$mgh + \frac{1}{2}mv_0^2 = \frac{1}{2}kd^2 + \mu_k mgL + \mu_k mgd$$

$$\frac{1}{2}kd^2 = mgh + \frac{1}{2}mv_0^2 - \mu_k mg(L+d)$$

$$k = \frac{2mgh}{d^2} + \frac{mv_0^2}{d^2} - \frac{2\mu_k mg}{d^2}(L+d)$$

$$k = 67 \text{ N/m}$$

b) For the mass to move back to the left, the spring force must overcome the maximum value of the force of static friction opposing the motion.

$$f_{s \max} = \mu_s n = \mu_s mg = 27.4 \text{ N}$$

$$|\vec{F}_k| = k|\Delta x| = kd = 268 \text{ N}$$

$$f_{s \max} < |\vec{F}_k(d)|$$

Looks like this spring at this compression can easily overcome static friction. The block will be launched back to the left (though it won't make it back up the hill).

2 (a)

$$[F] = [A][x^4] \Rightarrow [A] = \frac{N}{m^4} \text{ OR } \frac{kg}{s^2 m^3}$$

(b) $A = 4.00 \frac{N}{m^5}$. Find \vec{v}_f .

WORK - KE $W = \int_0^{1.4} 4x^4 dx = \frac{1}{2} m v_f^2 - 0$

$$\frac{4}{5} x^5 \Big|_0^{1.4} = \frac{1}{2} (3) v_f^2$$

$$4.3026 = \frac{1}{2} (3) v_f^2 \Rightarrow v_f = 1.69363 \frac{m}{s}$$

2D Motion $v_{0y} = 0$

$$v_x = v_f = 1.69 \frac{m}{s}$$

• get t from \hat{x} : $\Delta x = v_x t$

$$0.937 \text{ m} = (1.69363) t \Rightarrow t = 0.553 \text{ sec}$$

• \hat{y} : $v_{yf} = v_{yi} + a_y t = 0 - (9.8)(0.553) = -5.42 \frac{m}{s}$

$$\Rightarrow \vec{v}_f = (1.69 \hat{i} - 5.42 \hat{j}) \text{ m/s}$$

(c) $\tan^{-1} \left(\frac{v_{yf}}{v_x} \right) \Rightarrow 72.65^\circ$